



Crown Hanger and Harpoon Assembly Inspection

Issue

Potential situations in which a crown hanger and harpoon assembly may dislodge and fall to the drill floor.

Affected Units

All top drives with portable torque guides.

Recommendation

Canrig recommends inspection of all crown hanger and harpoon assemblies and implementation of at least two safety barriers to reduce the possibility that the assembly will dislodge and drop to the rig floor.

The following actions are recommended:

- Inspect the crown hanger and all welds for damage as soon as possible and prior to every rig move. The crown hanger must be held in place by the crown in accordance with the original design and construction engineering drawings.
- Inspect the gussets to ensure that the crown hanger cannot lift or twist out of position and fall. Make sure the bearing plates fit snug on the gussets. Also inspect the harpoon restraint cable and make sure it is properly secured to the crown or mast with minimal slack. (See Figure 1).

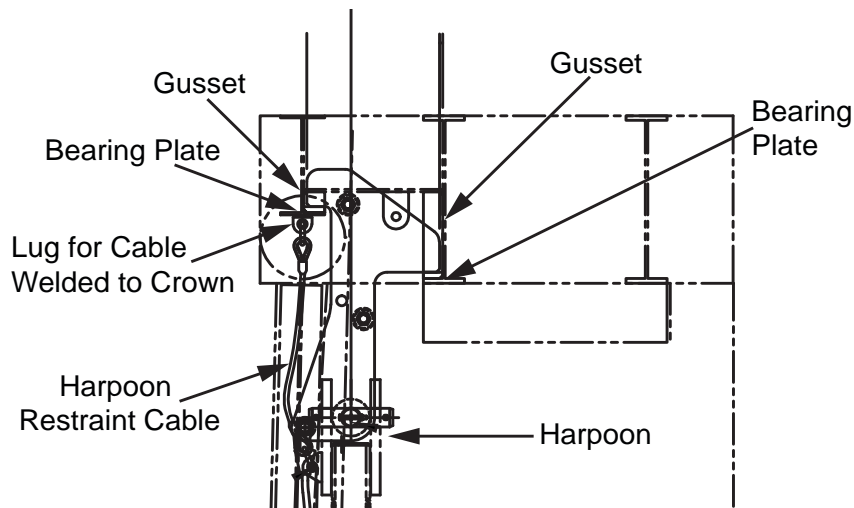

Figure 1: Inspect the gussets and harpoon restraint cable.

Model: All	April 17, 2013
Serial #: N/A	
Alert	

- Inspect the safety cable from the crown hanger plates to section 5 of the portable torque guide and also make sure the cable is properly secured (see Figure 2).

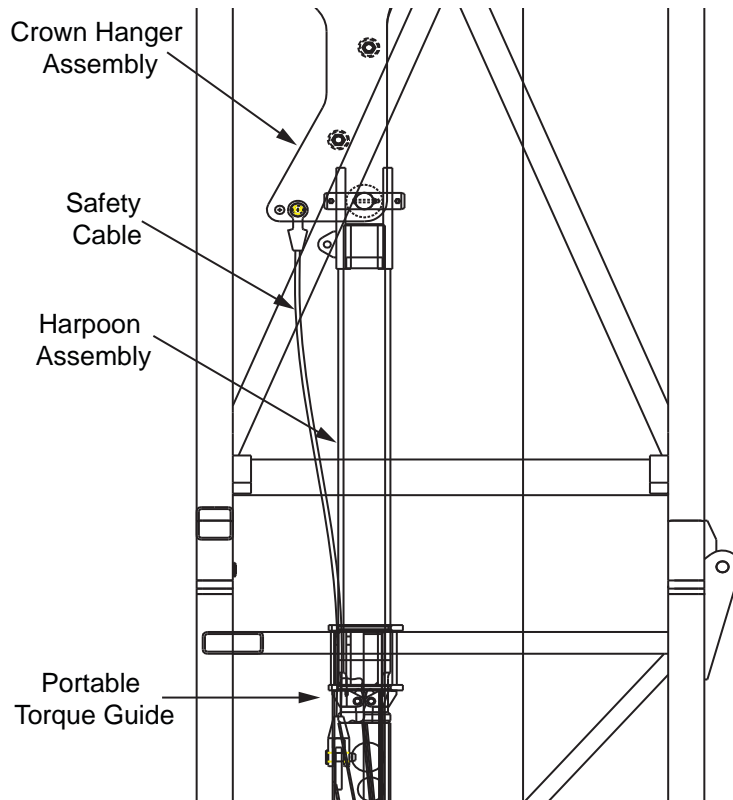

Figure 2: Inspect the crown hanger safety cable.

- The crown hanger and harpoon assemblies were designed to allow easy transfer of top drives between rigs. As top drives have become standard equipment for almost every rig, their mobility is often no longer necessary. For these instances, the crown hanger can be welded to the crown. Welding the crown hanger to the crown provides an additional barrier to reduce the possibility of the assembly dropping from the crown. For welding instructions, contact RigLine 24/7™.