



Model: EXI800	Jul. 30, 2019
Serial #: See affected units	
Product Bulletin # TDS-202 v 1.0	

EXI TD Lubrication Oil Cooler Bracket Upgrade

This document describes the process to upgrade the bracket that attaches the gearbox lubrication oil cooler to the gearbox housing.

Affected Units

This repair procedure applies to all older style EXI top drives with mechanical driven lubrication pumps. In later model EXI top drives, the mechanical lubrication pump has been replaced with an electric motor driven lubrication pump.



Note: This repair procedure can be done while the top drive is installed in the mast. Only a few items are disassembled from the top drive during this upgrade procedure. See "Safety Precautions" below before performing this procedure.

Safety Precautions

- Only qualified personnel should perform the procedures described in this bulletin.
- Only qualified welders shall perform the welding with qualified weld procedures.
- Complete a Job Safety Analysis (JSA) before starting the procedures outlined in this document.
- Ensure personnel completing the procedures outlined in this document are wearing appropriate Personal Protective Equipment (PPE).
- Perform Lock-out/Tag-out (LOTO) to isolate all power sources before servicing this equipment.
- Keep a clean spill bucket and oil spill clean-up material close by. Clean-up any oils spills immediately to avoid slipping hazards.

Procedure

Follow steps below to perform the cooler upgrade.

Removing the Cooler from the Top Drive

1. Disconnect the inlet and outlet hoses from the cooler unit. Immediately cap the hoses and the oil cooler ports.



Note: There is no stop valve in the lubrication system; therefore there will be a strong oil flow once the hose fittings are loosened. Use a clean bucket to catch the spill.

2. Disconnect the hoses from the hydraulic fan motor and cap both the hoses and the motor ports.
3. Secure the cooler with a lifting strap to the bracket or suspend it with an air hoist to prevent it from dropping.
4. Remove the six (6) bolts holding the cooler to the cooler bracket as shown in Figure 1 below.

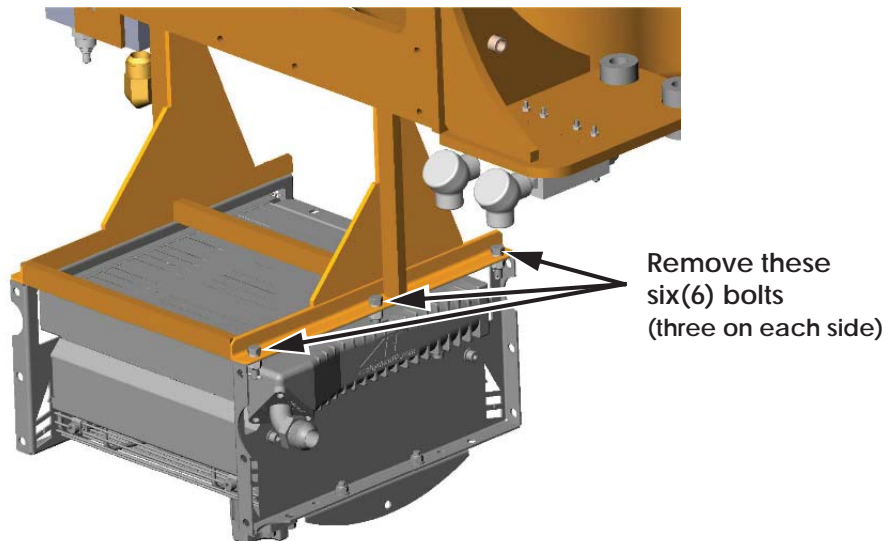

Figure 1: Remove Six (6) Bolts

5. Remove the cooler from the mounting frame.

Cooler Modification

1. Remove both side plates from the cooler as shown in Figure 2 below.

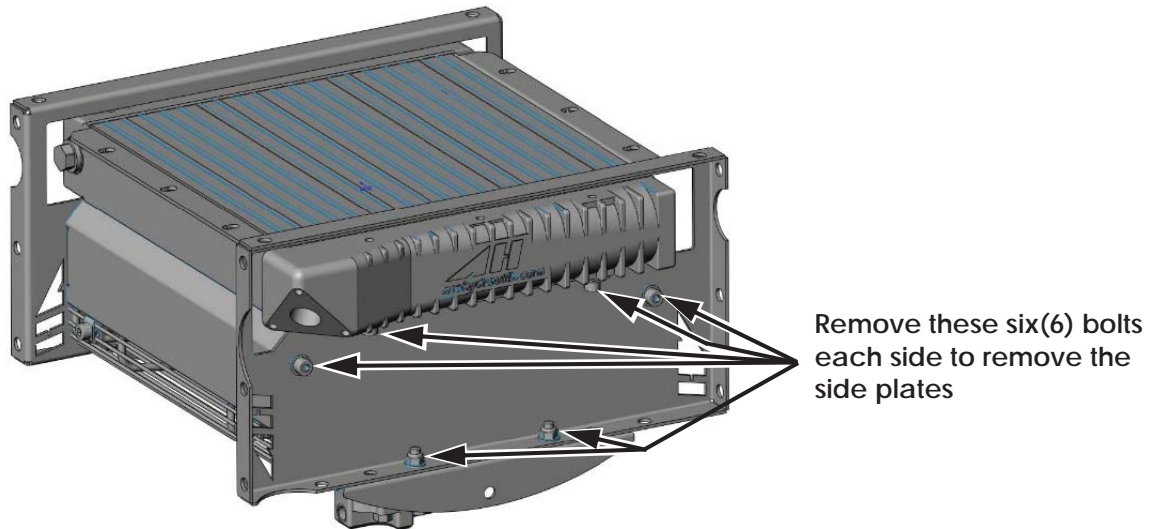

Figure 2: Remove Six (6) Bolts Each Side

2. Cut both side plates and discard top portion as shown in Figure 3 below.



Note: Deburr the edges after cutting the side plates.

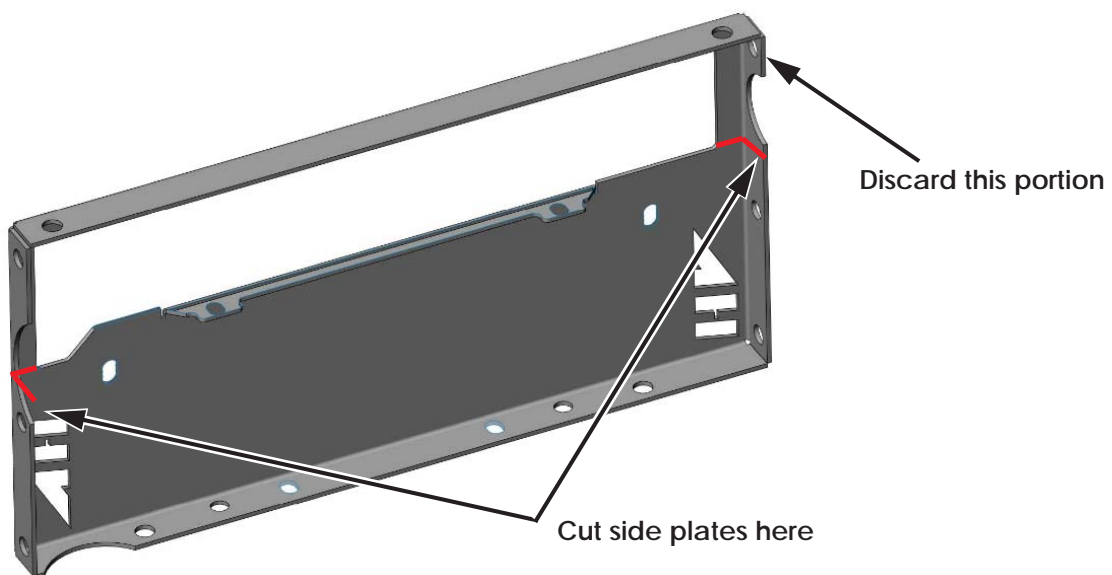

Figure 3: Cut both Side Plates

3. Position and weld two stiffener angles to each side plate as shown in Figure 4 below.

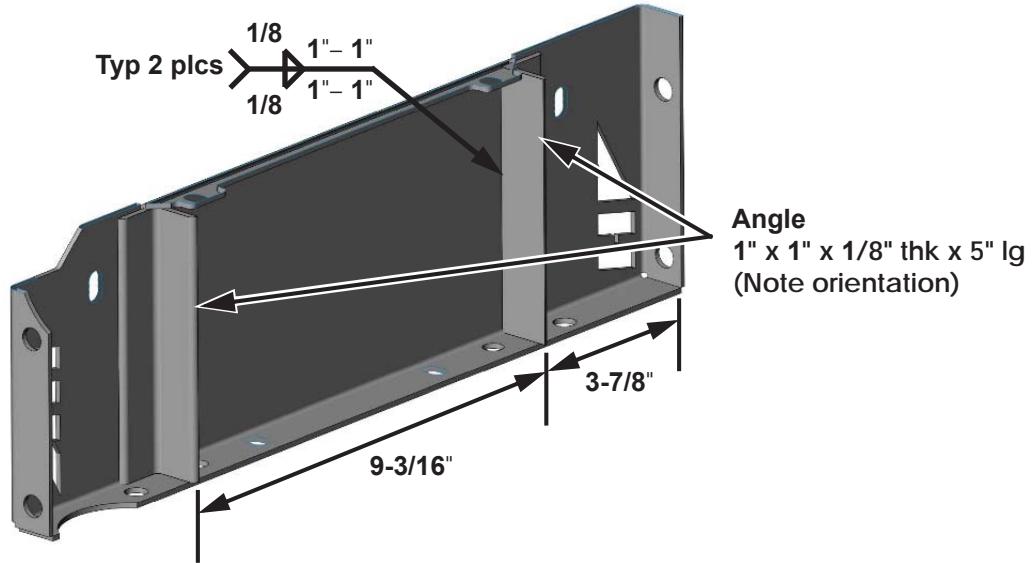

Figure 4: Weld Two Stiffener Angles

4. Bolt the side plates back onto the cooler. See Figure 8 on page 8.

Mounting Bracket Modification



Note: Perform this modification without removing the bracket from the top drive.

1. Cut two 2" x 1" x 1/8" thick x 12" long angle iron as per the sketch shown in Figure 5 below. (ASTM A36 or equivalent material).

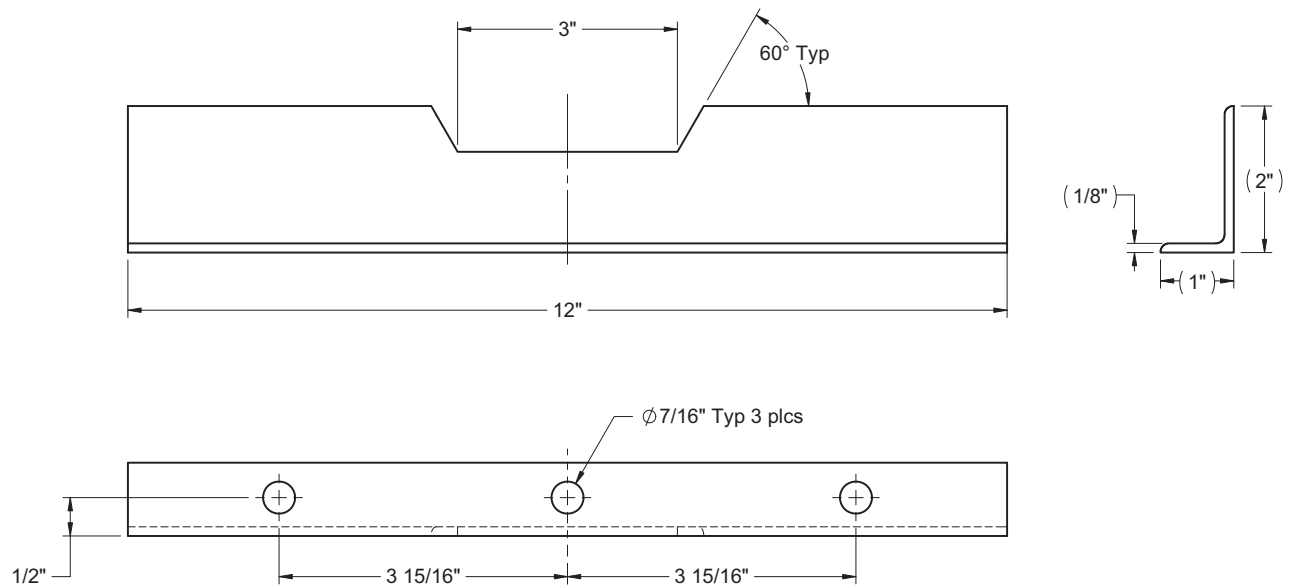

Figure 5: Mounting Bracket Modification

2. Manufacture two straps from 1" wide x 1/8" thick flat bar (ASTM A36 or equivalent material) as per sketch shown in Figure 6 below.

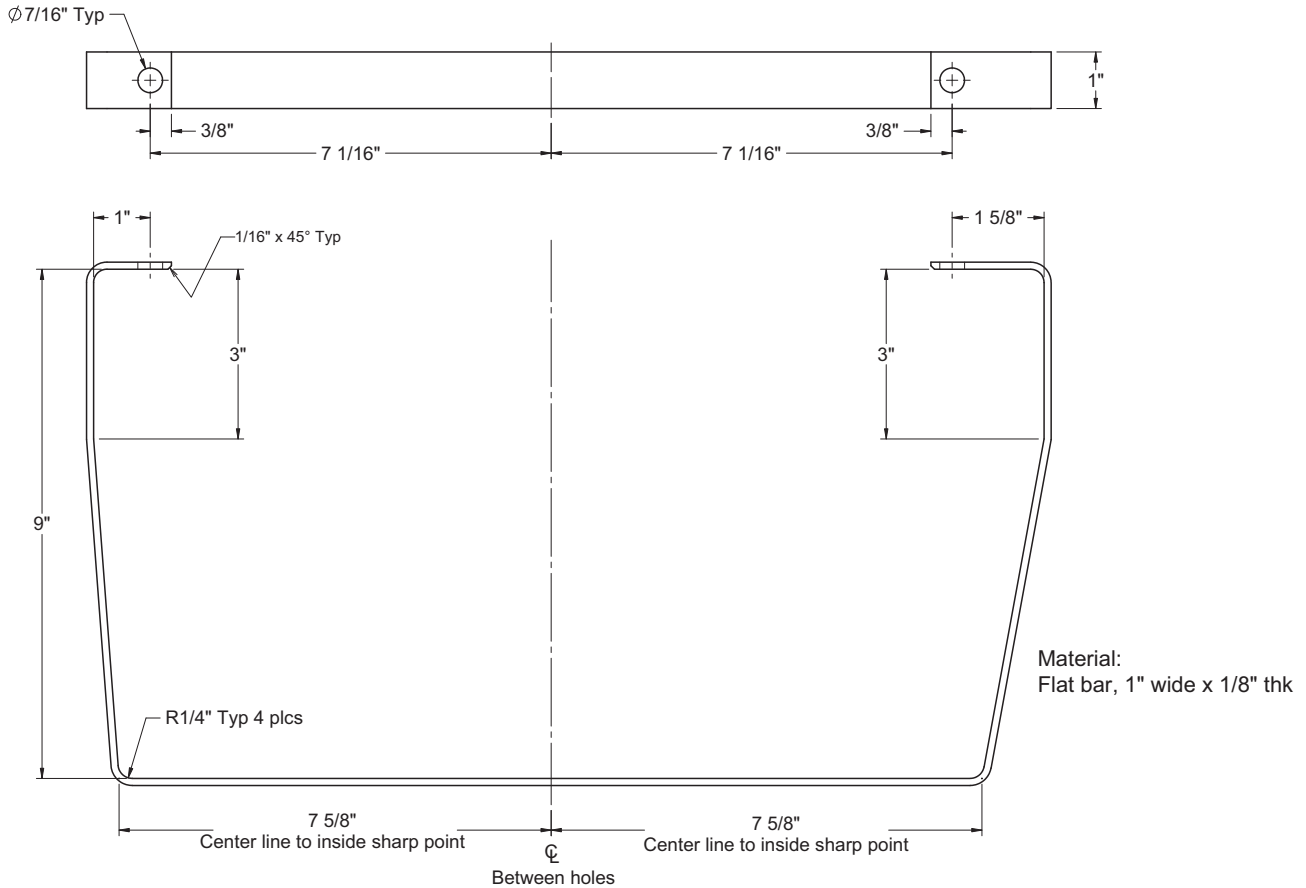

Figure 6: Straps

- Position the angles (from Step 1 on page 5) on the bracket and weld them in position as shown in the sketch in Figure 7. Use a weld procedure suitable for ASTM A36 or equivalent.

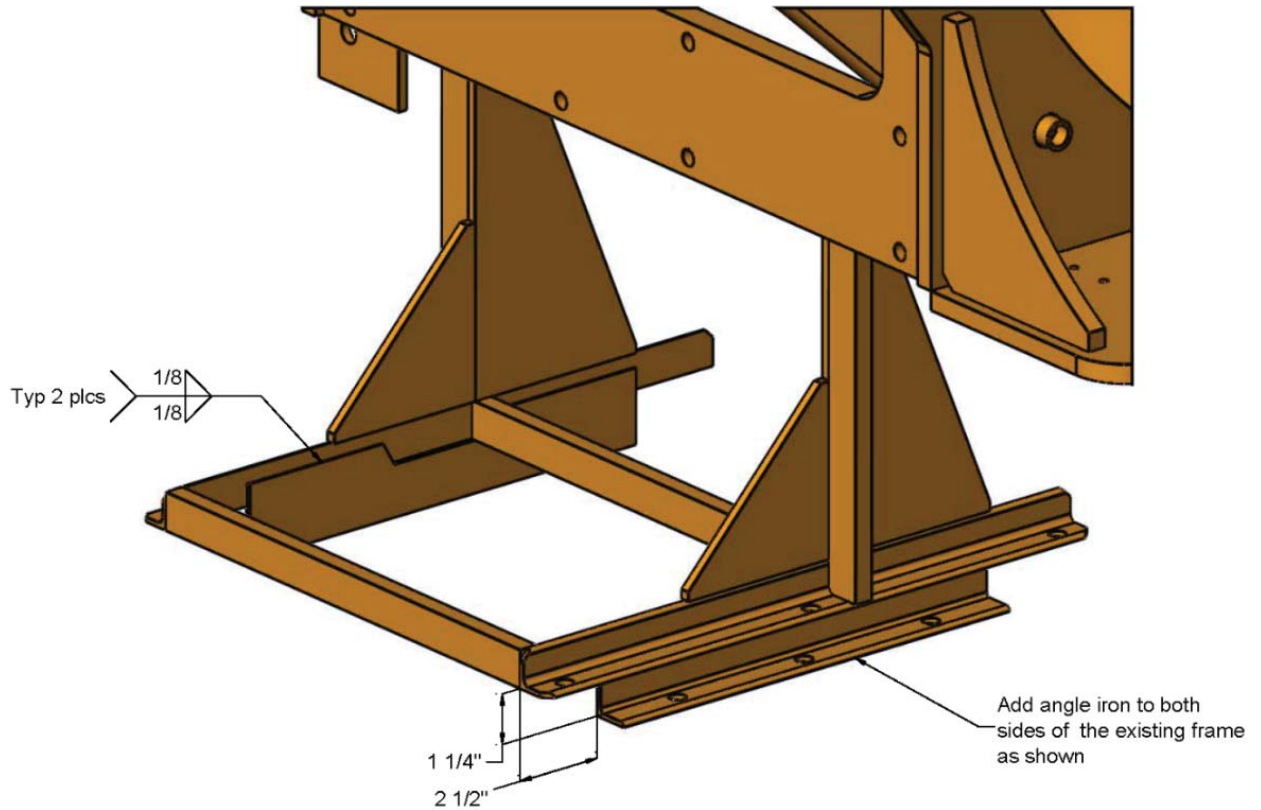

Figure 7: Welding Angles

- MPI the welds.
- Paint the modified cooler frame and the two straps Tesco yellow (RAL#1006).

Cooler Installation

1. Inspect the M8 threaded holes in the top for the cooler core to ensure the threads are in a good condition. Also, verify the dimensions from hole to hole and confirm they match the holes in the angles previously welded to the frame. See Figure 8 below.

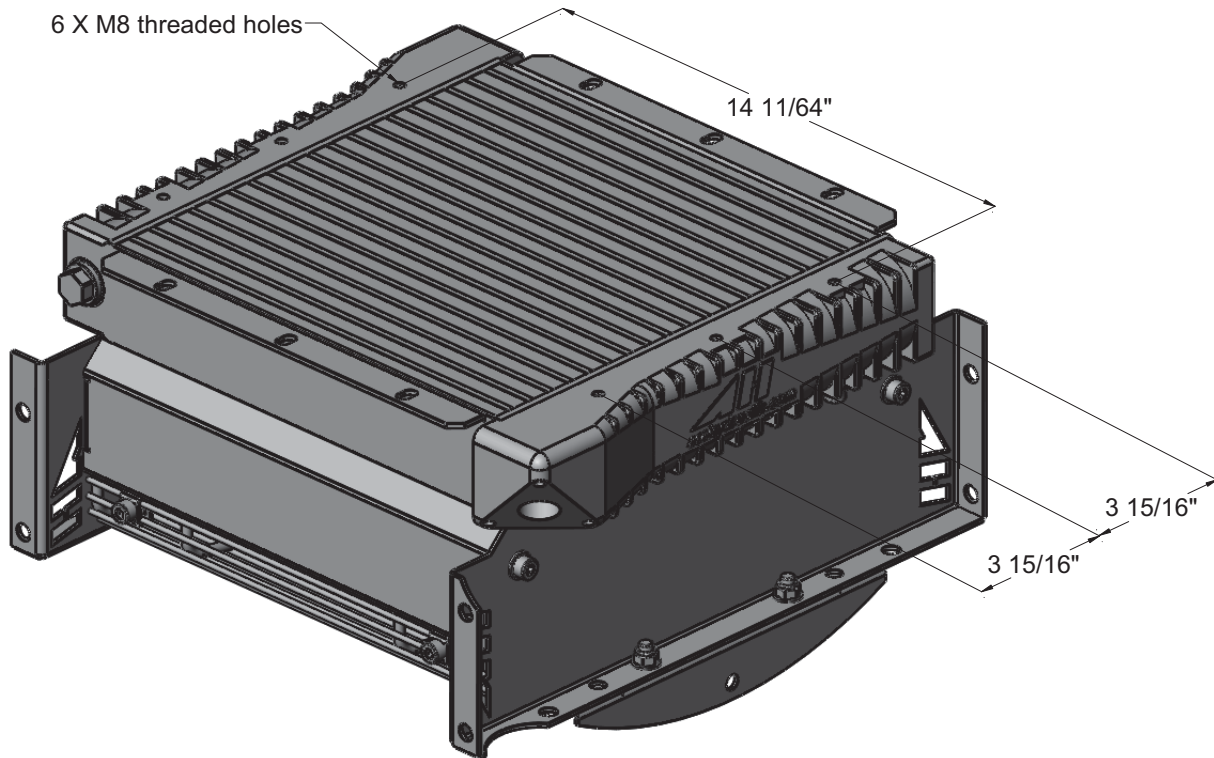

Figure 8: Inspect Threads and Hole-to-Hole Dimensions

2. Install the cooler and the straps onto the frame using six M8 x 25mm long drilled Hex head bolts and flat washers. Torque the bolts to 150 in· lb (17 N· m). Apply Loctite 243 and lock wire to the bolts. The straps serve as a secondary retention for the cooler assembly. See Figure 9 below.



Note: The rear strap is turned 180° around to clear the cooler.

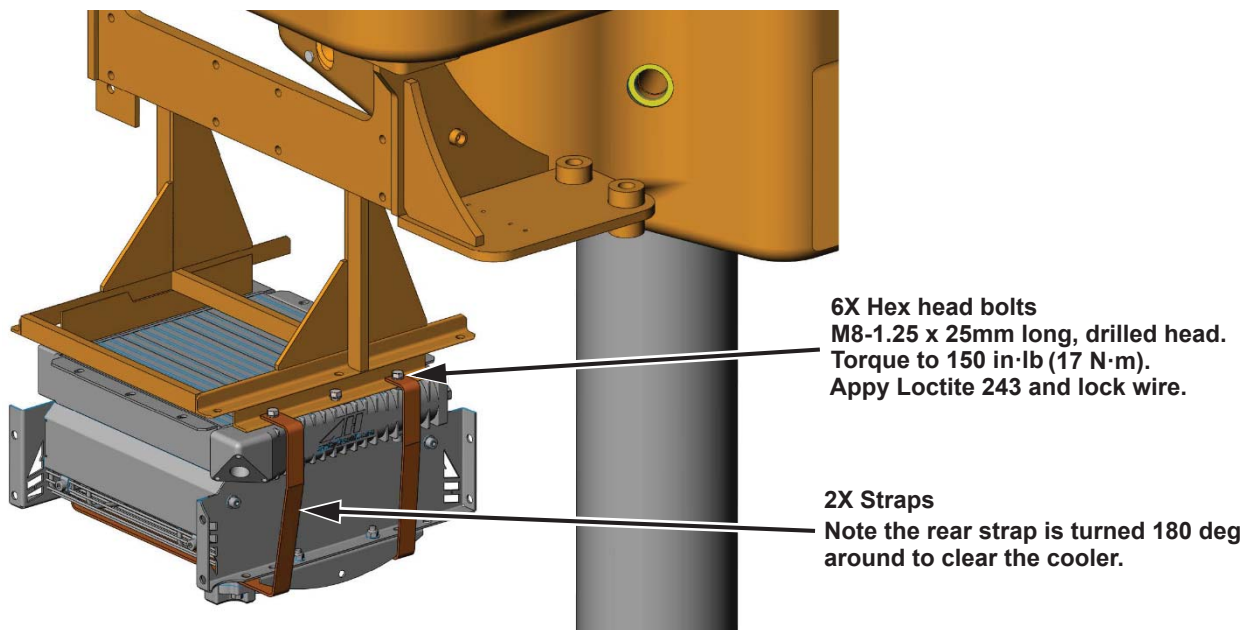

Figure 9: Install Cooler and Straps

3. Remove the caps from the hoses and connect them to the cooler.
4. Check and fill lubrication oil to account for spills if necessary.
5. Remove LOTO and test the equipment.