



Top Drive Guide Runner Shims

Issue

The shims used on the guide runners can become loose and dropped if the fasteners securing the shims break.

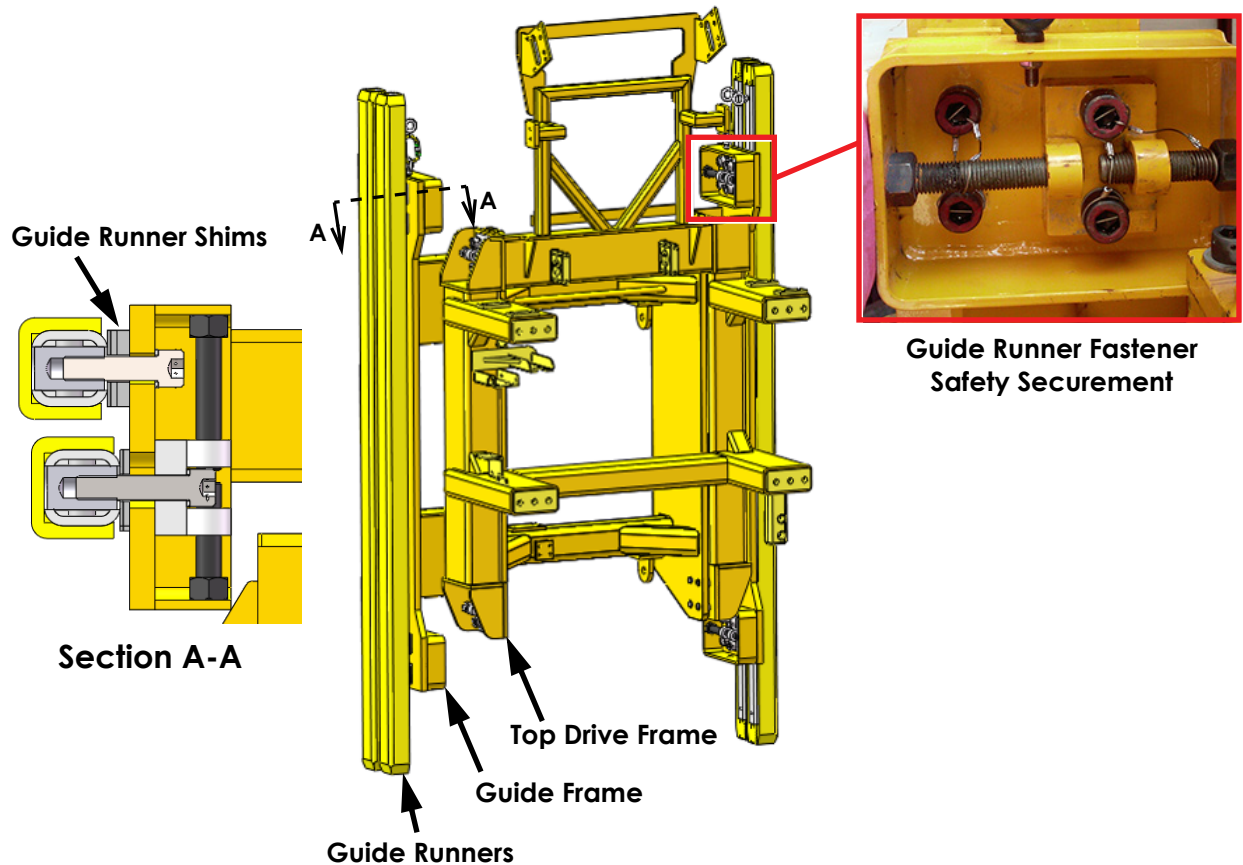

Figure 1: Guide Runner Shims Location

Affected Top Drives

- All Canrig Top Drives



Model: All	Mar. 20, 2020
Serial #: All	
Alert	

Recommended Action

1. Inspect the guide runner assemblies. Ensure all the fasteners are properly torqued and installed with Nord-Lock washer and safety securement (1/16" wire rope). Verify the safety securement for the shims (1/8" wire rope) are installed and intact if guide runner shims were upgraded per Canrig product bulletin TDS-156.
2. If the wire rope securing the fasteners is damaged or broken, inspect the fasteners for any damage or cracks. Replace any worn or damaged fasteners with new pieces. Use new Nord-Lock washer and Loctite® 242 when installing fasteners.
3. Canrig recommends using safety securement on the guide runner shims (refer to Canrig product bulletin TDS-156). Contact RIGLINE 24/7™ to order new guide runner shims (refer to Table 1) which can be secured using 1/8" wire rope as shown in Figure 2.

Table 1: Guide Runner Shims

Part No.	Description
DT11169-125	SHIM, 1/8, GUIDE RUNNER, TOP DRIVE
DT11169-250	SHIM, 1/4, GUIDE RUNNER, TOP DRIVE
DT11169-500	SHIM, 1/2, GUIDE RUNNER, TOP DRIVE
DT11169-750	SHIM, 3/4, GUIDE RUNNER, TOP DRIVE
DT11169-1000	SHIM, 1, GUIDE RUNNER, TOP DRIVE

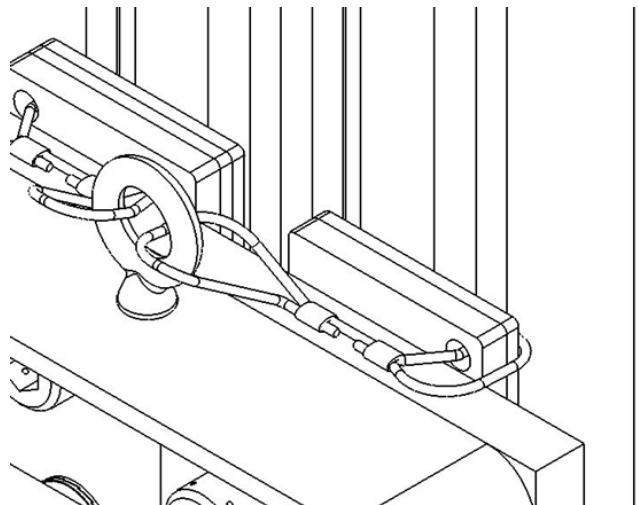

Figure 2: Guide runner shims with safety securement

4. The guide runner assembly should be inspected weekly as part of the drop object prevention inspection. Refer to Section 4B of the top drive manual for recommended top drive inspection schedule.



Model: All	Jan. 25, 2016
Serial #: See Affected Units	
Product Bulletin # TDS-156	

Guide Runner Shims Upgrade

A newly designed shim for the guide runner assembly is now available. This new shim has provision for secondary retention.

Affected Units

Top drive units that use the following Guide Runner Rig Interface assemblies are eligible for this upgrade:

Canrig Assembly Numbers		
AY20618	AY11367	AY17425
AY11386	AY13301	AY17854
AY11876	AY14965	AY17160
AY11534	AY13809	AY17505
AY15059	AY12972	AY17611
AY15618	AY14920	AY20239
AY13158	AY13279	AY18069
AY17248	AY16659	AY20230
AY15421	AY19243	AY11554

Ordering Upgrade Kit

Customers who wish to upgrade should contact RigLine 24/7™ Support to order the Guide Runner Upgrade Kit.

The following table lists the old part numbers for the shims that can be replaced. Refer to the table under “Upgrade Kit Ordering Information” on page 2, for information on the new shim part numbers and other parts included in the kit.

Old Part Number	Description
DT11689-125	SHIM 1/8, RUNNER/FRAME
DT11689-250	SHIM 1/4, RUNNER/FRAME
DT11689-500	SHIM 1/2, RUNNER/FRAME
DT11689-750	SHIM 3/4, RUNNER/FRAME
DT11689-1000	SHIM 1, RUNNER/FRAME

Upgrade Kit Ordering Information

ITEM	QTY	PART#	DESCRIPTION
1	See note	DT11169-125	SHIM, 1/8, GUIDE RUNNER, TOP DRIVE
2	See note	DT11169-250	SHIM, 1/4, GUIDE RUNNER, TOP DRIVE
3	See note	DT11169-500	SHIM, 1/2, GUIDE RUNNER, TOP DRIVE
4	See note	DT11169-750	SHIM, 3/4, GUIDE RUNNER, TOP DRIVE
5	See note	DT11169-1000	SHIM, 1, GUIDE RUNNER, TOP DRIVE
6	10FT	M10022	WIRE ROPE, 1/8, 7 X 19, STAINLESS
7	16	M19-3009-010	FERRULE, 1/8, OVAL, ALUMINIUM
8	2	M19-4012-010	EYEBOLT, SHLD TYPE, 1/2-13UNC x 1 1/2
9	2	LN-0500NC-GR8	LOCKNUT, 1/2-13UNC, GR8, STOVER



Note: For replacement items 1–5, quantities depend on the amount of shims required for guide runners.

Guide Runner Configurations

The following guide runner configurations are available. The position of the shim holes will vary accordingly. See Figure 1 and Figure 2.

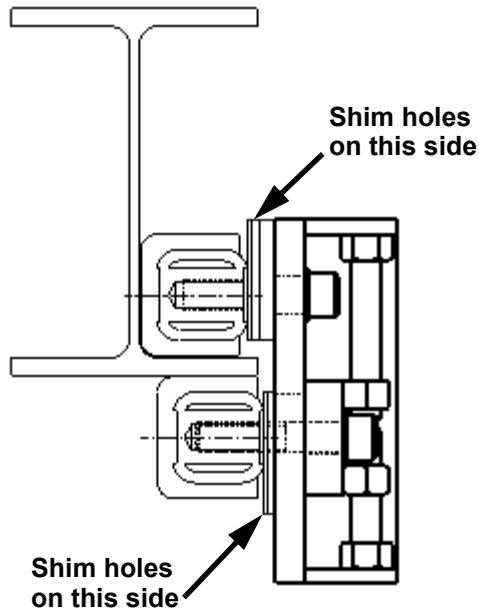

Figure 1: Guide Runners in Between a Flange

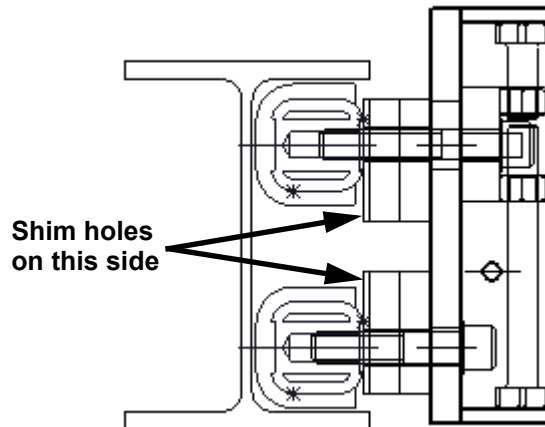

Figure 2: Guide Runners in Between a W-Flange

Installation

See Figure 3 below for an exploded view indicating correct orientation of the shims during installation.

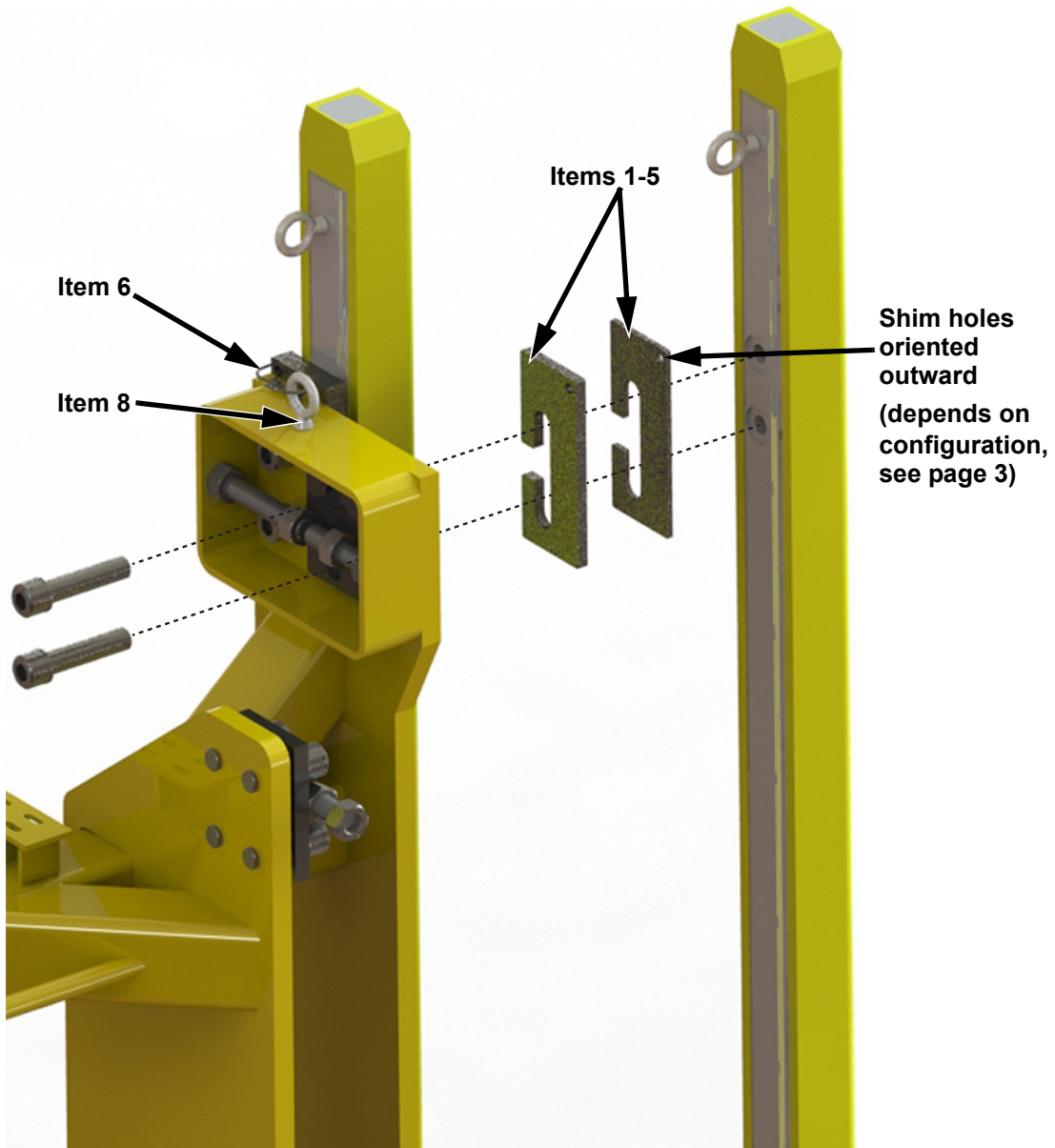

Figure 3: Exploded View



Note: See items in "Upgrade Kit Ordering Information" on page 2.

Safety Wiring (Shims)

Route safety wire (1/8"), through the eyebolt and stacked shim holes and use corresponding ferrules as shown in Figure 4.

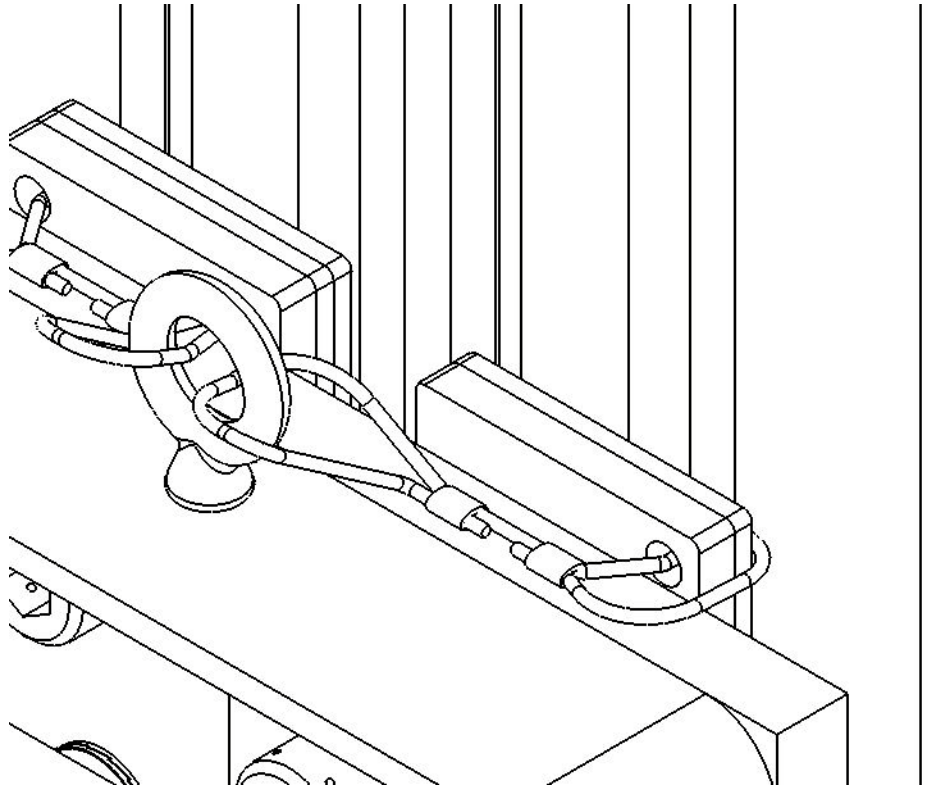

Figure 4: Safety Wiring



Note:

The 1" bolts that keep the guide runners and shims together must be torqued at 848 ft-lb.

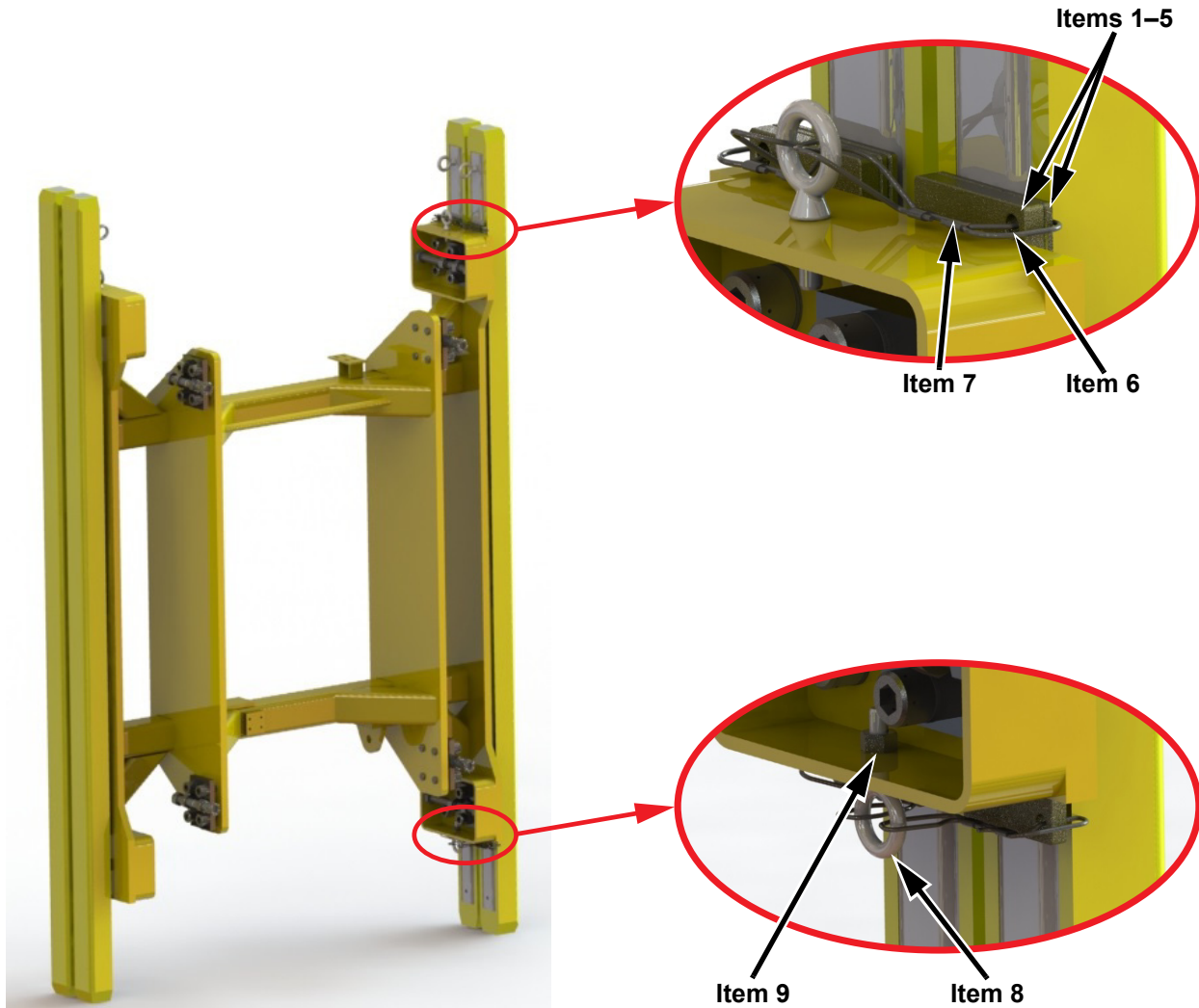

Figure 5: Orientation of Shim Holes



Note: See items in "Upgrade Kit Ordering Information" on page 2.

- If the guide runner configuration is as shown in Figure 1 on page 3, then the holes on the shims are oriented outward. See Figure 5.
- If the guide runner configuration is as shown in Figure 2 on page 3, then the holes on the shims are oriented inward.

Safety Wiring (Bolts)

For secondary retention, add safety wire to the socket-head bolts. Use 1/16" wire and ferrules and route as shown in Figure 6. Also, safety wire top socket-head bolts to the eyelet.

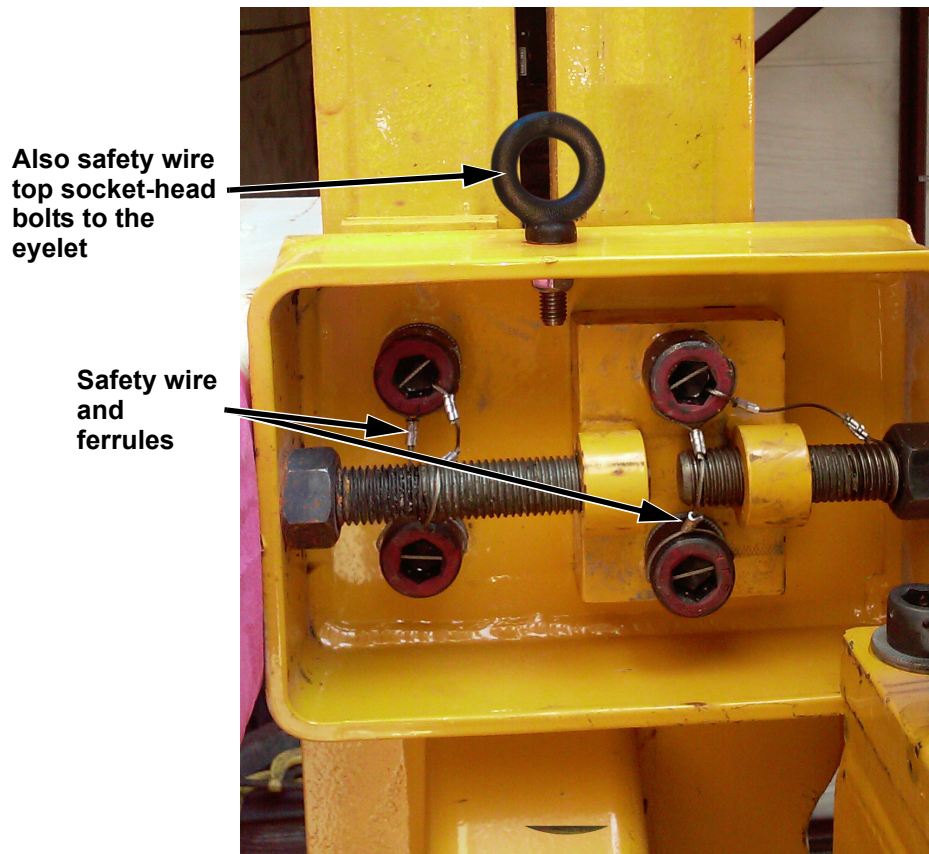

Figure 6: Safety wiring for socket-head bolts.